



DVD-2000H

Service Manual - DVD-2000H

SAFETY PRECAUTIONS GENERAL GUIDELINES

1. When servicing, observe the original lead dress. If a short circuit is found, replace all parts which have been overheated or damaged by the short circuit.
2. After servicing, see to it that all the protective devices such as insulation barriers, insulation papers shields are properly installed.
3. After servicing, make the following leakage current checks to prevent the customer from being exposed to shock hazards.

LEAKAGE CURRENT COLD CHECK

1. Unplug the AC cord and connect a jumper between the two prongs on the plug.
2. Measure the resistance value, with an ohmmeter, between the jumpered AC plug and each exposed metallic cabinet part on the equipment such as screwheads, connectors, control shafts, etc. When the exposed metallic part has a return path to the chassis, the reading should be between $1M\Omega$ and $5.2M\Omega$. When the exposed metal does not have a return path to the chassis, the reading must be ∞ .

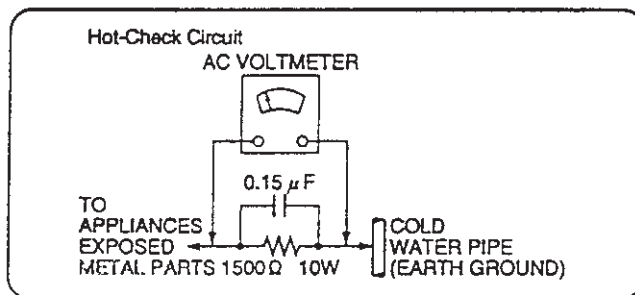

Figure 1

LEAKAGE CURRENT HOT CHECK (See Figure 1.)

1. Plug the AC cord directly into the AC outlet. Do not use an isolation transformer for this check.
2. Connect a $1.5k\Omega$, 10 watts resistor, in parallel with a $0.15\mu F$ capacitors, between each exposed metallic part on the set and a good earth ground such as a water pipe, as shown in Figure 1.
3. Use an AC voltmeter, with 1000 ohms/volt or more sensitivity, to measure the potential across the resistor.
4. Check each exposed metallic part, and measure the voltage at each point.
5. Reverse the AC plug in the AC outlet and repeat each of the above measurements.
6. The potential at any point should not exceed 0.75 volts RMS. A leakage current tester (Simpson Model 229 or equivalent) may be used to make the hot checks, leakage current must not exceed 1/2 milliamp. In case a measurement is outside of the limits specified, there is a possibility of a shock hazard, and the equipment should be repaired and rechecked before it is returned to the customer.

PREVENTION OF ELECTRO STATIC DISCHARGE (ESD) TO ELECTROSTATICALLY SENSITIVE (ES) DEVICES

Some semiconductor (solid state) devices can be damaged easily by static electricity. Such components commonly are called Electrostatically Sensitive (ES) Devices. Examples of typical ES devices are integrated circuits and some field-effect transistors and semiconductor "chip" components. The following techniques should be used to help reduce the incidence of component damage caused by electro static discharge (ESD).

1. Immediately before handling any semiconductor component or semiconductor-equipped assembly, drain off any ESD on your body by touching a known earth ground. Alternatively, obtain and wear a commercially available discharging ESD wrist strap, which should be removed for potential shock reasons prior to applying power to the unit under test.
2. After removing an electrical assembly equipped with ES devices, place the assembly on a conductive surface such as aluminum foil, to prevent electrostatic charge buildup or exposure of the assembly.
3. Use only a grounded-tip soldering iron to solder or unsolder ES devices.
4. Use only an anti-static solder removal device. Some solder removal devices not classified as "anti-static (ESD protected)" can generate electrical charge sufficient to damage ES devices.
5. Do not use freon-propelled chemicals. These can generate electrical charges sufficient to damage ES devices.
6. Do not remove a replacement ES device from its protective package until immediately before you are ready to install it. (Most replacement ES devices are packaged with leads electrically shorted together by conductive foam, aluminum foil or comparable conductive material).
7. Immediately before removing the protective material from the leads of a replacement ES device, touch the protective material to the chassis or circuit assembly into which the device will be installed.
CAUTION: Be sure no power is applied to the chassis or circuit, and observe all other safety precautions.
8. Minimize bodily motions when handling unpackaged replacement ES devices. (Otherwise harniss motion such as the brushing together of your clothes fabric or the lifting of your foot from a carpeted floor can generate static electricity (ESD) sufficient to damage an ES device).

IMPORTANT SAFETY NOTICE

There are special components used in this equipment which are important for safety. These parts are marked by Δ in the schematic diagrams, Exploded Views and replacement parts list. It is essential that these critical parts should be replaced with manufacturer's specified parts to prevent shock, fire, or other hazards. Do not modify the original design without permission of manufacturer.

PRECAUTION OF LASER DIODE

CAUTION:

This unit utilizes a class I laser. Invisible laser radiation is emitted from the optical pickup lens when the unit is turned on:

1. Do not look directly into the pickup lens.
2. Do not use optical instruments to look at the pickup lens.
3. Do not adjust the preset variable resistor on the optical pickup.
4. Do not disassemble the optical pickup unit.
5. If the optical pickup is replaced, use the manufactures specified replacement pickup only.
6. Use of control or adjustment or performance of procedures other than those specified herein may result in hazardous radiation exposure.

HANDLING PRECAUTIONS FOR TRAVERSE DECK

The laser diode in the optical pickup may break down due to potential difference caused by static electricity of clothes or human body.

So be careful of electrostatic break down during repair of the optical pickup.

Handling of optical pickup

1. Do not subject the optical pickup to static electricity as it is extremely sensitive to electrical shock.
2. To prevent the breakdown of the laser diode, an antistatic shorting pin is inserted into the flexible board (FPC Board).
When removing or connecting the short pin, finish the job in as short times as possible.
3. Be careful not to apply excessive stress to the flexible board (FPC Board)
4. Do not turn the variable resistor (Laser power adjustment). It has already been adjusted.

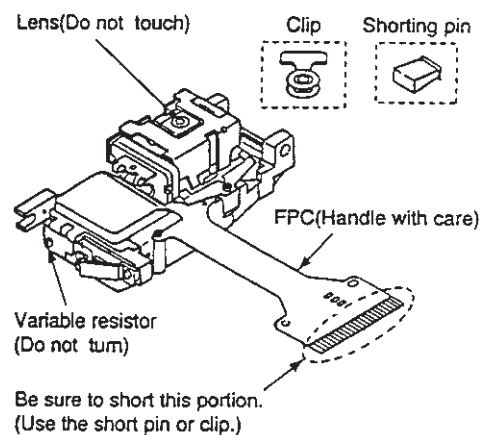

Grounding for electrostatic breakdown prevention

1. **Human body grounding**
Use the antistatic wrist strap to discharge the static electricity from your body.
2. **Work table grounding**
Put a conductive material (sheet) or steel sheet on the area where the optical pickup is placed and ground the sheet.

Caution:

The static electricity of your clothes will not be grounded through the wrist strap. So take care not to let your clothes touch the optical pickup.

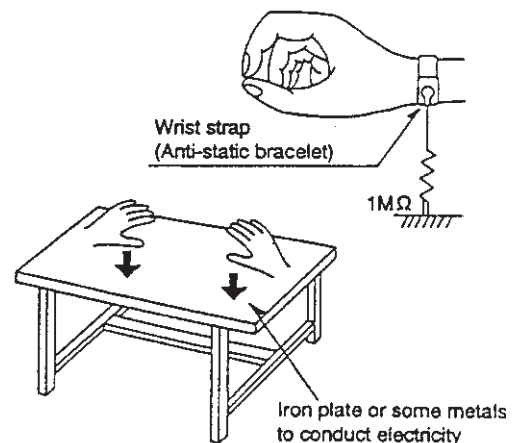

Self-Diagnosis Function for Service Number Display

This unit has a self-diagnosis function which detects a problem or malfunction within the unit and displays its corresponding service number on the display of the unit.

The Service Information Display Mode is used by the technician to help determine the source of a malfunction. To operate the Service Information Display Mode during servicing, press the [0] (remote control-unit) button while pressing the OPEN/CLOSE and STILL/PAUSE buttons simultaneously. Please refer to the table shown below when a service number has appeared.

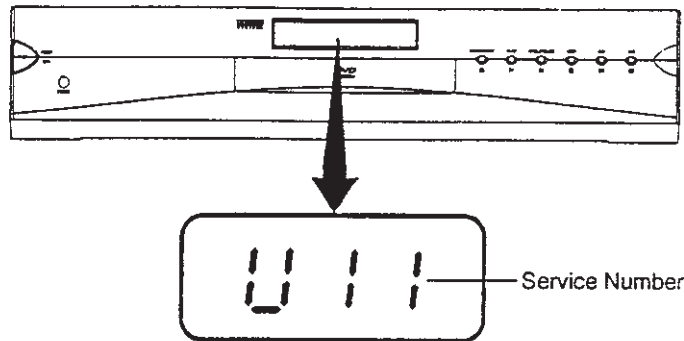

Mode	Service Number	Player State	Check Point
During Operation	U11	FOCUS TROUBLE	IC2001, IC2511, IC5201, Pick-up
	H01	TRAY LOADING TROUBLE	IC2001, IC2511, Loading motor
	H02	SPINDLE SERVO TROUBLE	Disc motor, IC2501, IC2001
	H03	TRAVERSE TROUBLE	Traverse motor, IC2511, IC2001
	H04	TRACKING SERVO TROUBLE	IC2001, IC2501, IC5201, Pick-up Disc
	H05	SEEK TROUBLE	Traverse motor, IC2511, IC2001
Service Information Display	F0**	DISC FORMAT ERROR	Disc
	F1**	DISC CODE ERROR	Disc
	F2**	DECODER LSI ERROR	IC3001, IC3201
	F3**	SDRAM ERROR	IC3051, IC6301, IC7051
	F4**	IIC BUS ERROR	IC2001, IC3201, IC4201, IC5201, IC6201, IC6312, IC7001
	F5**	DSC ERROR	IC2001
	F6**	ECC ERROR	IC7001
	F7**	MICRO PROCESSOR ERROR	IC6001, IC6201
F8**	MICRO PROCESSOR ERROR	IC6001, IC6201	

SERVICE INFORMATION

1. Lighting Confirmation Function of Display Tube

SETTING PROCEDURES

During pressing both [STILL/PAUSE] and [OPEN/CLOSE] buttons on the DVD Player, push [9] key of the Remote Controller and then all of the display lights, and the [POWER] button is pressed to release.

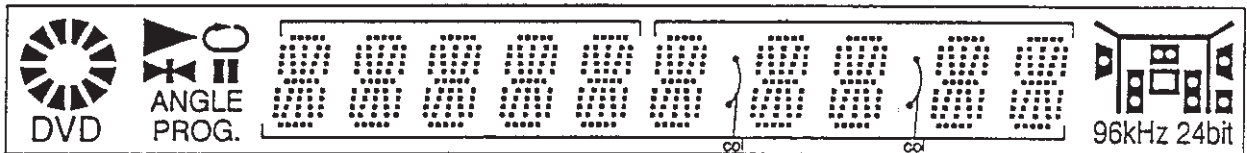

2. Initialization of the DVD Player

Make initialization of the DVD Player when replacing the Main p.c. board, Operation p.c. board and etc.

INITIALIZATION PROCEDURES

During pressing both [STILL/PAUSE] and [SKIP/SEARCH ◀◀] buttons simultaneously on the DVD Player, push [POWER] button on the DVD Player so that the unit is initialized (Factory shipping condition).

The letter of [INITIALIZED] is displayed on the screen.

[CAUTION]

When the initialization has been made, the contents of user initial setting is lost.

Therefore, before making initialization, previously memorize the contents of user Initial setting and set the initial setting again after initialization.

3. After Repair (Transport Method in Repair Service)

After repair, settle the traverse unit at elevation up position.

SETTLING PROCEDURES

1. Turn the power on.
2. Press the [OPEN/CLOSE] button to close the tray.
3. Turn the power off.
4. Disconnect the power plug from the power outlet.

[CAUTION]

Do not close the tray manually after disconnect the power plug from the power outlet in tray open condition.

In this case, the traverse is not settled at elevation up position (stand-by) so that you can't transport the unit.

4. In Case of Stopping Operation During Playback

When the unit stop during playback (no operation button operates, etc.), press the [POWER] button. After 5 seconds later the power will be turned off.

When the power is turned on again and the same state appears, the unit may be in trouble. Or, in case stopping operation when the specific disc is used, the cause of trouble may be in the disc itself.

5. Operation Lock Function in Salse Demonstration

This function is used to prevent the disc from loss in the salse demonstration.

When this function is set, It is not able to eject the disc and turn the power off.

SETTING PROCEDURES

During pressing the [STOP] button of the DVD Player, push the [POWER] button of the Remote Controller to make the Lock function operate.

Disconnect the power plug from the power outlet to reset this function.

6. Lens Cleaning

For cleaning, wipe the Pick-up softly with the new cotton cloth damped with ethyl alcohol.

Never wipe it strongly or the wrong influence will have on the glass coating of the Pick-up.

After cleaning, be sure to check no dirt or dust on the lens surface.

Disassembly, Reassembly, Replacement and Adjustment Procedures

1. Disassembling and Reassembling the Casing Parts

1-1. Removing the Top Cover

1. Remove the 7 screws, and remove the Top Cover
While spreading the left and right sides slightly, remove the top cover while lifting the rear portion.

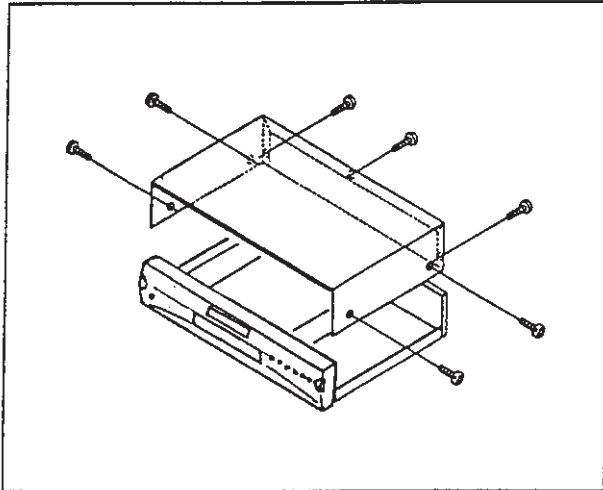

Fig. 1-1-1 Removal of the Top Cover

1-2. Removing the Front Panel

If the tray can be opened electrically.

1. Perform this operation after the top cover has already been removed.
2. Press the Open/Close button and open the tray.
If there is a disc in the tray, remove the disc, taking care not to damage it.
Then remove the tray panel attached to the front edge of the tray.

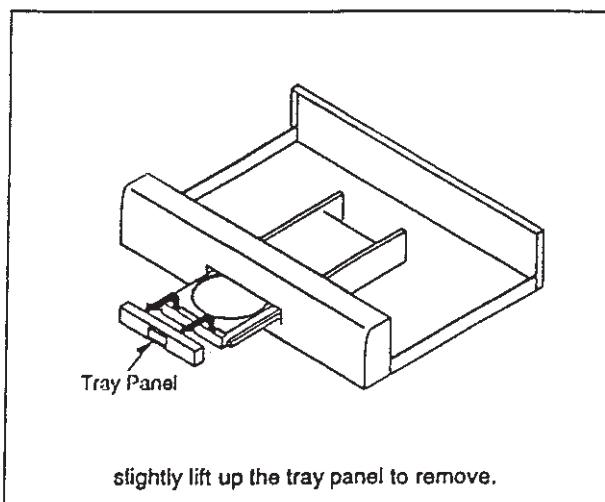

Fig. 1-2-1 Removal of the Tray Panel

3. Press the Open/Close button and close the tray, then unplug the power cord.
4. Remove the flexible cables which connect the printed circuit board on the front panel with the main unit.
Then remove the 2 screws on the bracket of the front panel.

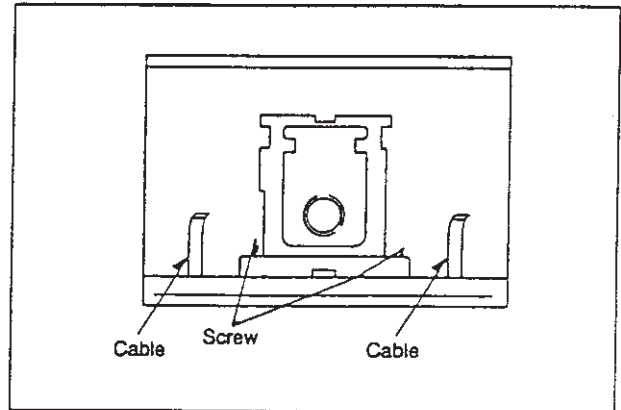

Fig. 1-2-2 Removal of the Front Panel

5. Unlock the 3 tabs on the bottom of the front panel, the 2 tabs on both the left and right and the 2 tabs on the traverse Unit, and remove the front panel.

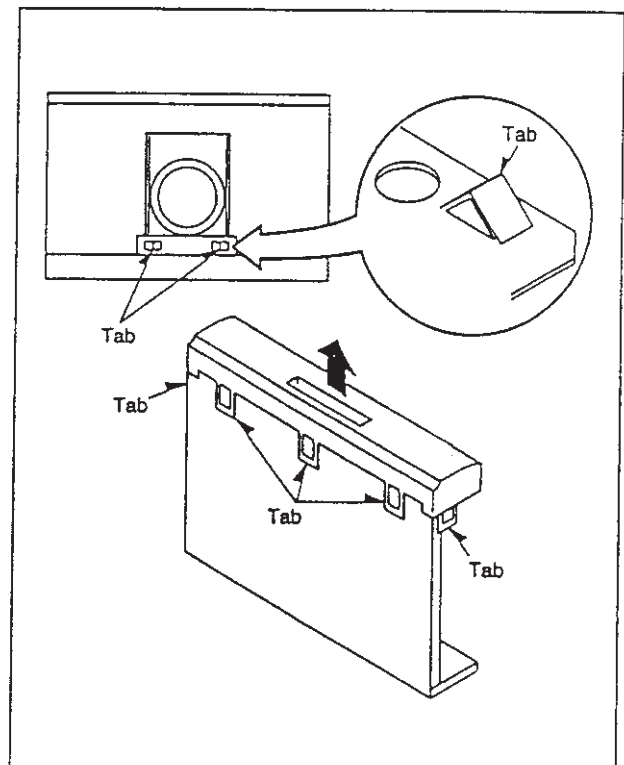

Fig. 1-2-3 Location of Tabs on the Front Panel

If the tray cannot be opened electrically (If the disc does not eject even after pushing the Open/Close button).

1. Perform this procedure after the top cover has already been removed as shown in Fig. A.
2. Remove the 4 screws on the Clamp Support Plate as shown in Fig. B.
3. If there is a disc in the tray, remove the disc, taking care not to damage it as shown in Fig. C. Refer to "How to Remove the Disc on the Tray in Trouble" with respect to the above procedures.
4. You will see a portion of the rotary cam from the mechanism moving hole at the bottom of the unit. Use a pair of tweezers to move this section to the "Tray Open" position.

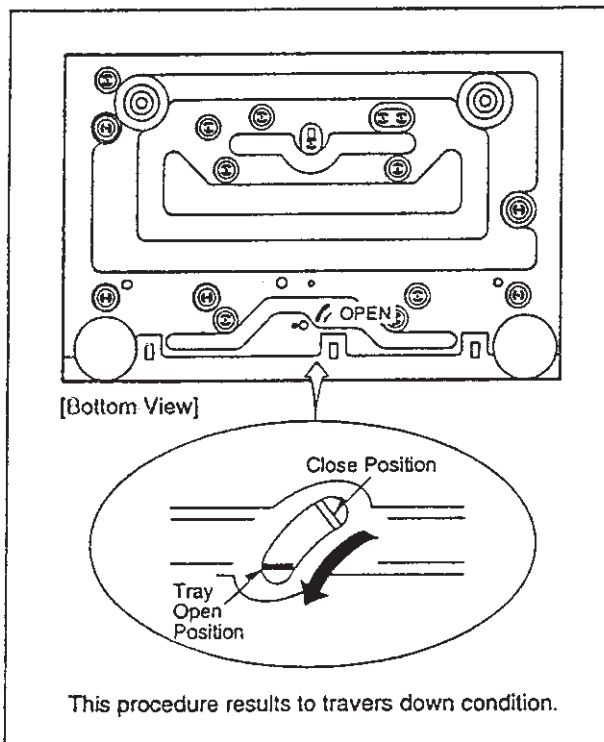

Fig. 1-2-4 Tray Open Position

5. The tray can be moved by hand to the open position.

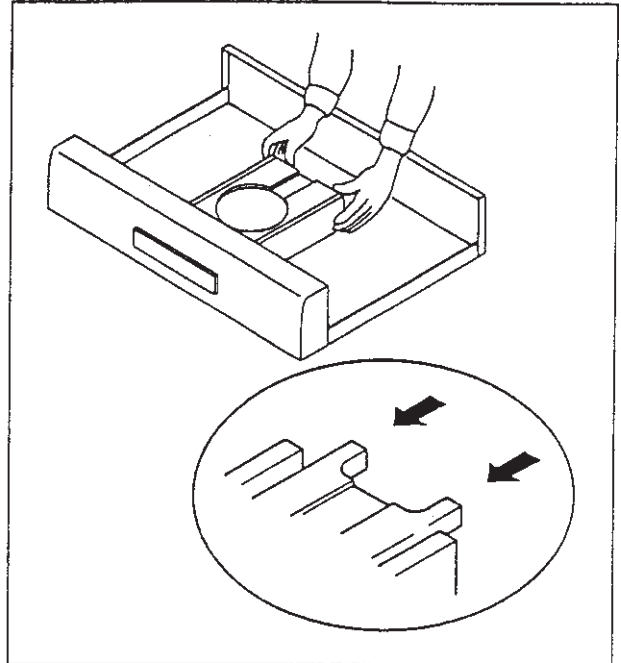

Fig. 1-2-5 Manual Movement of the Tray

6. Remove the tray panel attached to the front edge of the tray as shown in Fig. 1-2-1. Then, load the tray manually and remove the front panel as shown in Fig. 1-2-2 and Fig. 1-2-3.

1-3. Reassembling the Casing Parts

1. Assemble in the reverse order used in the disassembly.

Please obey the following:

After repair is completed, use the following procedure to settled the Traverse Unit.

1. Push the power button and turn off the power. Verify that the stand-by lamp is on.
2. Unplug the power cord.
3. After the stand-by lamp has been on, the power cord is unplugged to settle the traverse Unit automatically.

SECTION 2 ADJUSTMENT PROCEDURES

How to Remove the Disc on the Tray in Trouble

When the Disc does not eject even after pushing the OPEN/CLOSE button, remove the Disc as follows.

1. Remove the 7 screws, and remove the Top Cover
While spreading the left and right sides slightly, remove the top cover while lifting the rear portion.

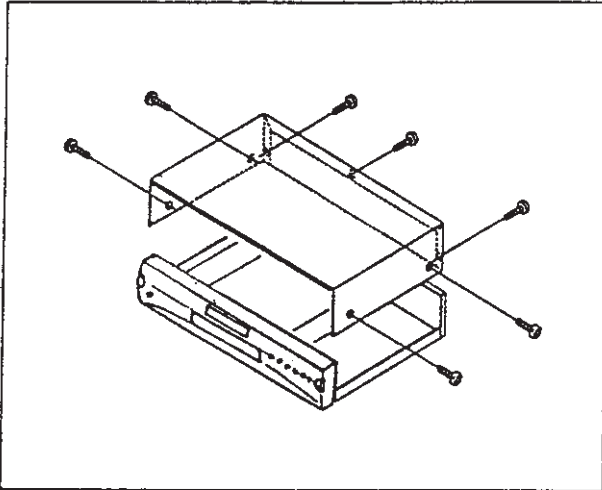

Fig. A Removal of the Top Cover

2. Remove the clamp support plate by removing the 4 screws.

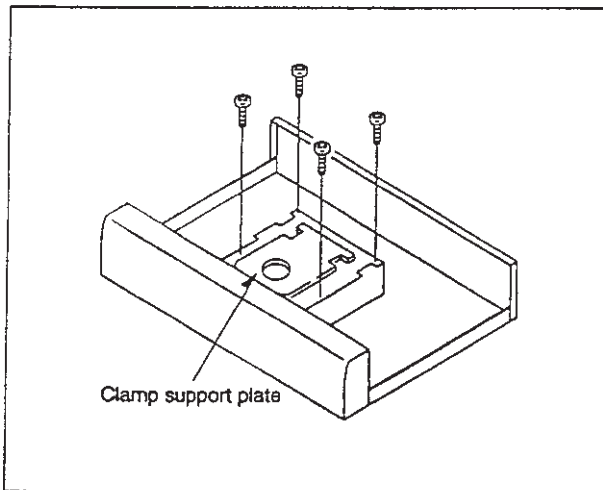

Fig. B Removal of the Clamp Support Plate

3. Remove the disc, taking care not to damage it.

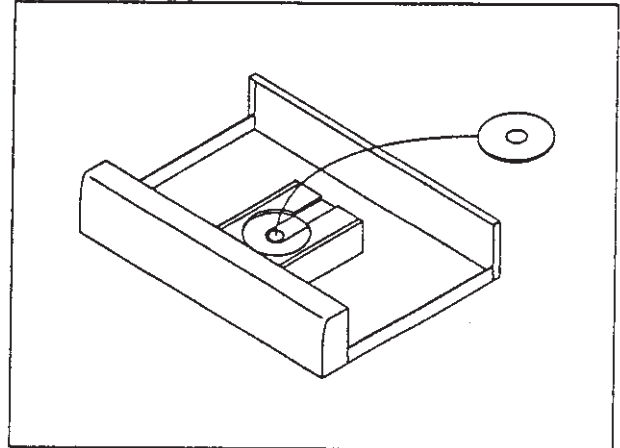

Fig. C Removal of the Disc

2. Disassembling and Reassembling the Loading Base

Please take proper care to prevent static electricity damage when touching the loading base. We recommend that you remove the entire loading base Unit before replacing the laser pick-up.

2-1. Removal of the Loading Base

1. Follow the "Top Cover," "Tray Panel" and "Front Panel" when removing the casing parts.

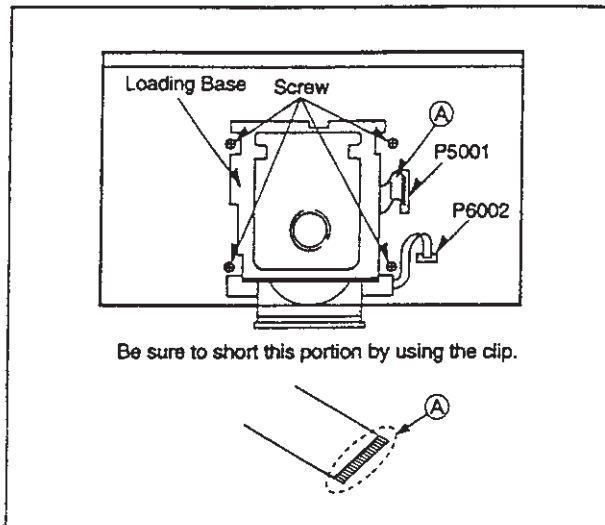

Fig. 2-1 Removal of the Loading Base

2. Remove the 2 Flexible Cables connecting the loading base and the main C.B.A. (Circuit Board Assembly) Static electricity destroys the laser diode. After removing the flexible cable (A), short the flexible cable (A) with a metal clip.
3. Remove the 4 screws attaching the Loading Base.

2-2. Disassembling the Clamp Support Plate and the Clamper

1. Remove the Clamp Support Plate from the Loading Base by removing the 4 screws.

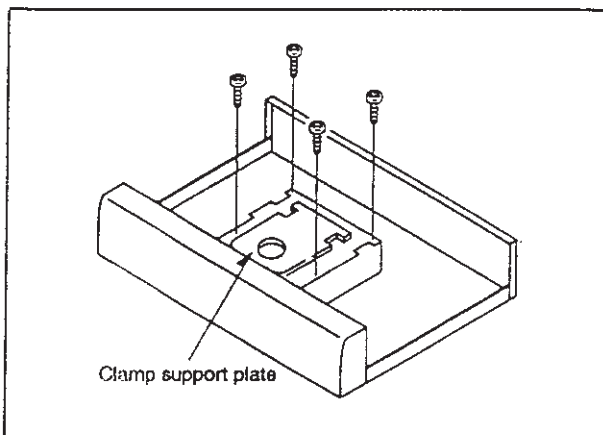

Fig. 2-2-1 Removal of the Clamp Support Plate

2. Remove the 4 screws.
3. Disassemble while unlocking the three tabs on the bottom of the clamper. Be careful not to damage these tabs.

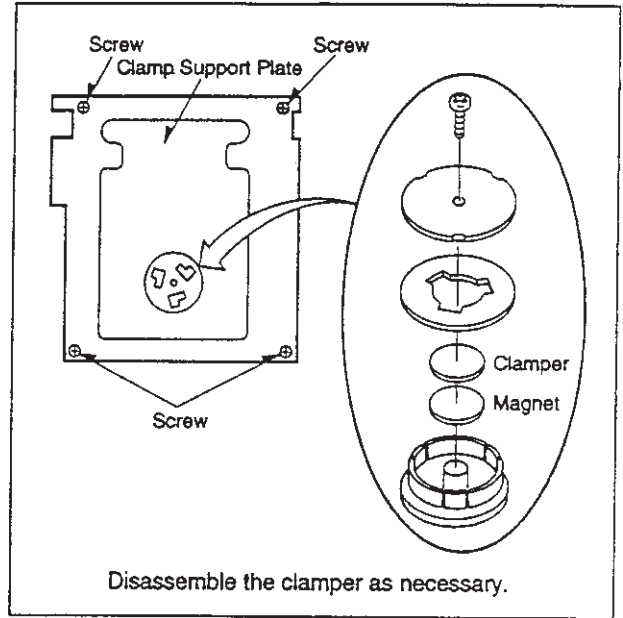

Fig. 2-2-2 Disassembly of the Clamper

2-3. Removing the Loading Tray

1. Move the portion of the Rotary Cam extending from the bottom of the loading base to the "Tray Open" position.

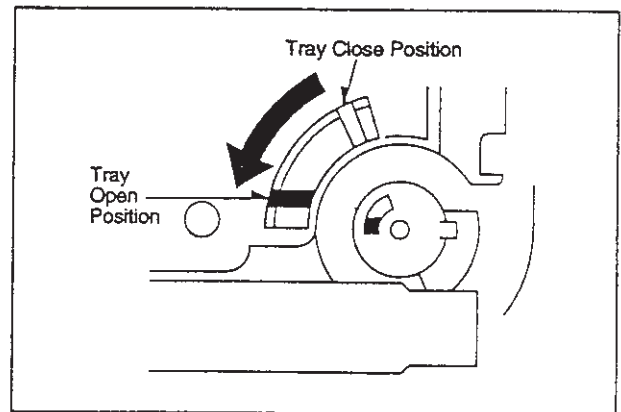

Fig. 2-3-1 Tray Open Position of the Rotary Cam

2. The tray can be manually moved to the open position.

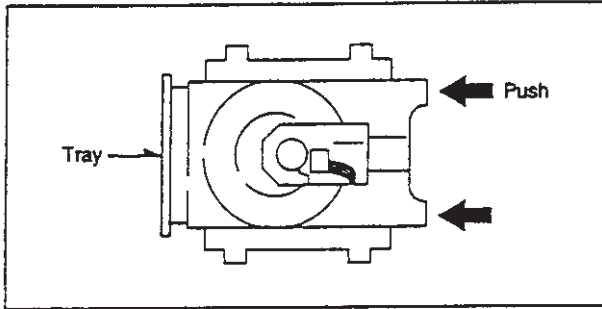

Fig. 2-3-2 Manual Movement of the Tray

3. The left and right catchers are locked so that the tray will not slip out. Therefore remove the tray while spreading these catchers outward.

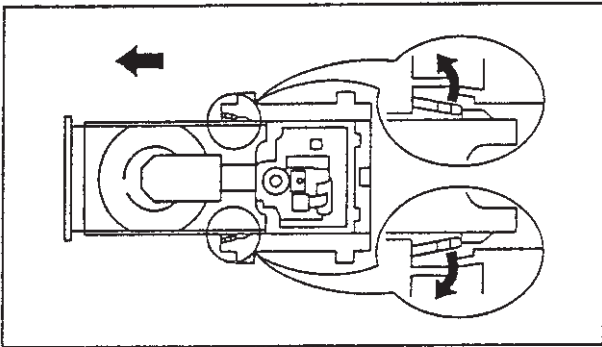

Fig. 2-3-3 Removal of the Tray

2-4. Removing the Traverse Unit

1. Remove the 2 screws setting the Rotary Support Plate Spring. Then remove the 2 screws fixing the Chassis Stoppers and the Springs (two each).

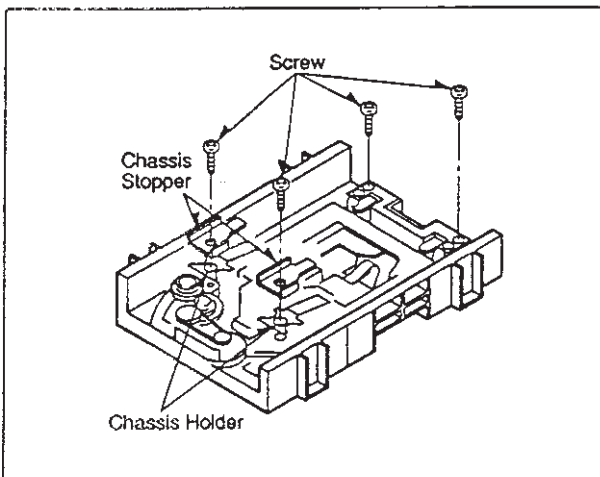

Fig. 2-4-1 Removal of the Traverse Unit

2. The Traverse Unit is connected to the Rotary Cam, slowly lift the back side (the side of Rotary Support Plate Springs) and remove.

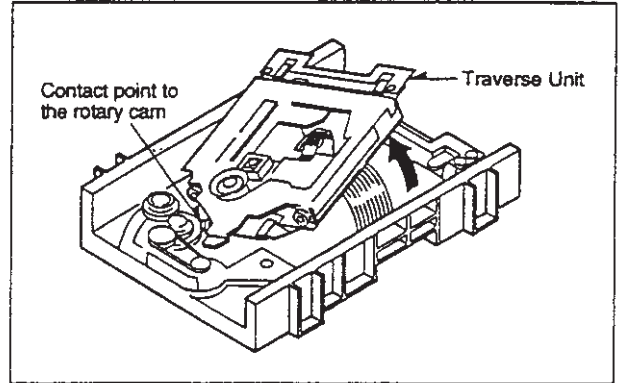

Fig. 2-4-2 Contact Point of the Traverse Unit and the Rotary Cam

2-5. Removing the Loading Section Parts

These parts can be removed even without taking out the Traverse Unit. Each gear and belt can be removed as shown in the figure below.

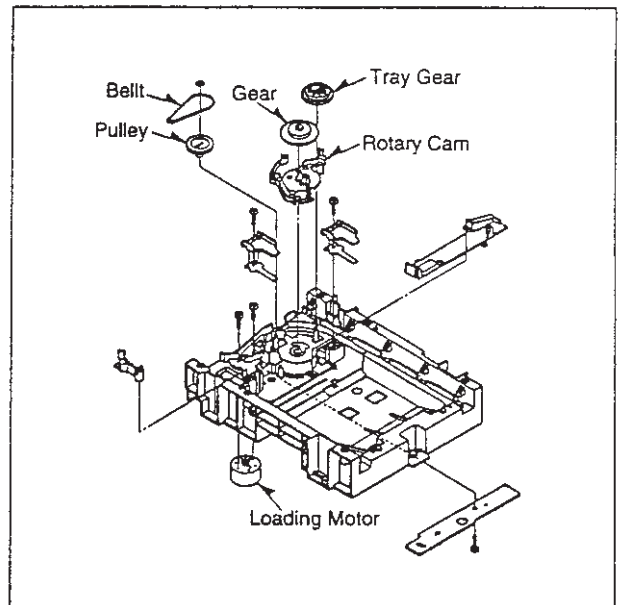

Fig. 2-5 Removal of the Loading Mechanism

2-6. Assembling the Loading Section Parts

Although the phases do not need to be aligned during assembly, please follow the order for assembly.

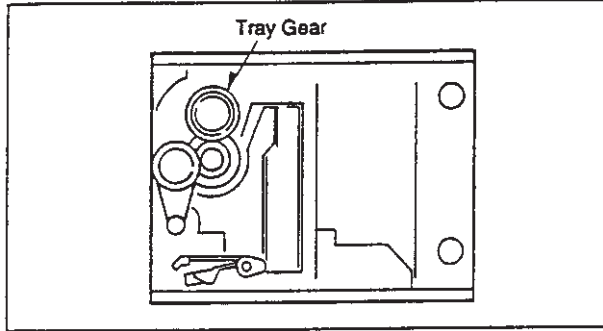

Fig. 2-6 Assembly of the Loading Mechanism

2-7. Assembling the Traverse Unit

1. Pull the Flexible Cable, which sticks out from the Traverse Unit, out from the inner side of the Loading Base.

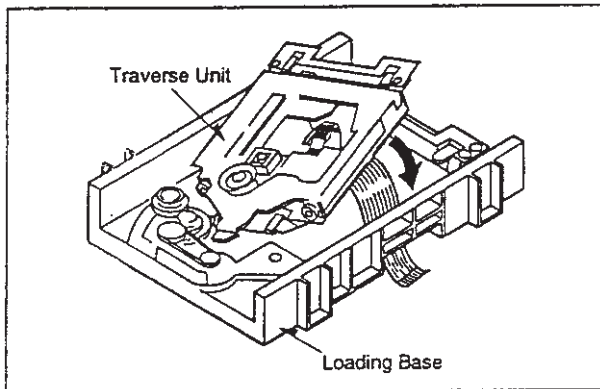

Fig. 2-7-1 Assembly of the Traverse Unit

2. Rotate the Tray Gear counterclockwise, then insert the end of the Traverse Unit into the groove in the Rotary Cam, and tighten the 4 screws.

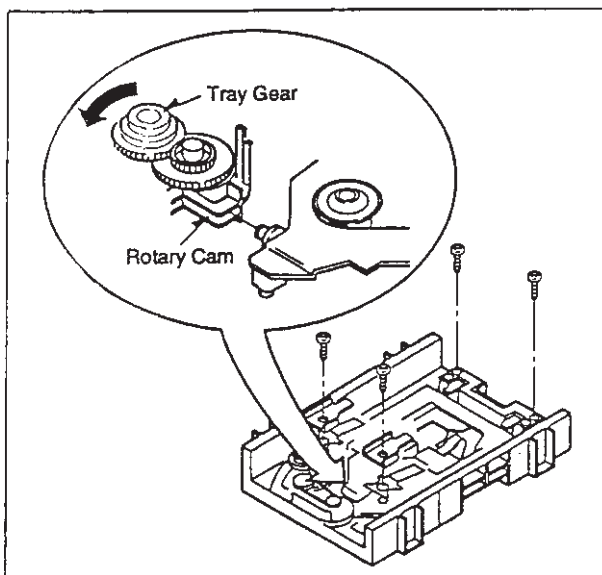

Fig. 2-7-2 Setting of the Traverse Unit and the Rotary Cam

2-8. Attaching the Loading Tray

1. Rotate the Tray Gear counterclockwise and verify that the Traverse Unit is at the lowest position.
2. Push the portion (A) of Rotary Cam in the direction of arrow.
3. Confirm that the Pawl of Rotary Cam is locked.

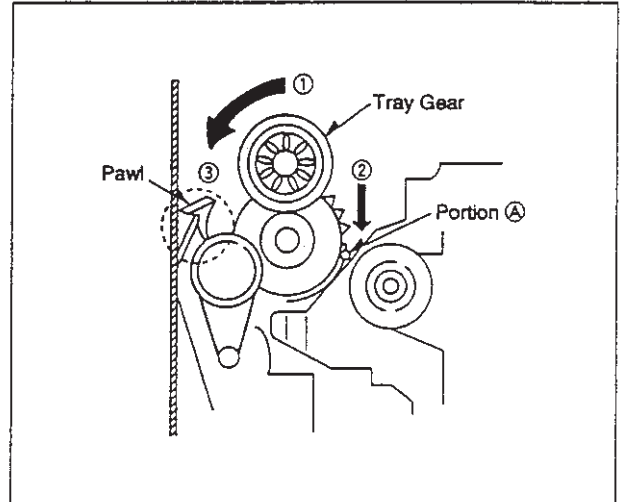

Fig. 2-8-1 Setting of the Tray

2. There is no phase alignment when inserting the tray. Insert the tray straight into the Loading Base.

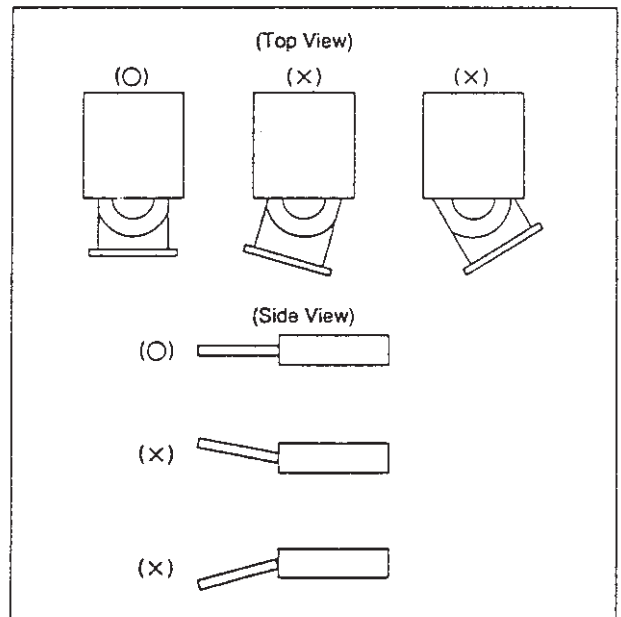

Fig. 2-8-2 Normal Setting of the Tray

2-9. Attaching the Clamp Support Plate

1. Attach the Clamp Support Plate and assemble the Loading Base.

3. Replacing the Main Parts of the Traverse Unit

This section describes the replacement of the main parts in the Traverse Unit, including the Laser Pick-Up, the Disc Motor, the Traverse Motor Unit.

Work should be performed after removing the Traverse Unit.

To Prevent Damage to the Laser Diode
Static electricity destroys the Laser Diode. Always take countermeasures to prevent static electricity damage when performing repairs around the Laser Pick-Up.

1. Do not touch the area around the Laser Pick-Up or the Actuator.
2. Do not check the Laser Diode with a tester or other device (the Laser Diode can be broken quite easily).
3. Short-Circuit the Laser Pick-Up
Solder the Land in the center of the flexible cable of the Laser Pick-Up. This will short-circuit the Laser Diode and help prevent damage from static electricity.

Caution:

Do not forget to remove the soldered Laser Diode short-circuit after finishing repair, and leave the circuit open.

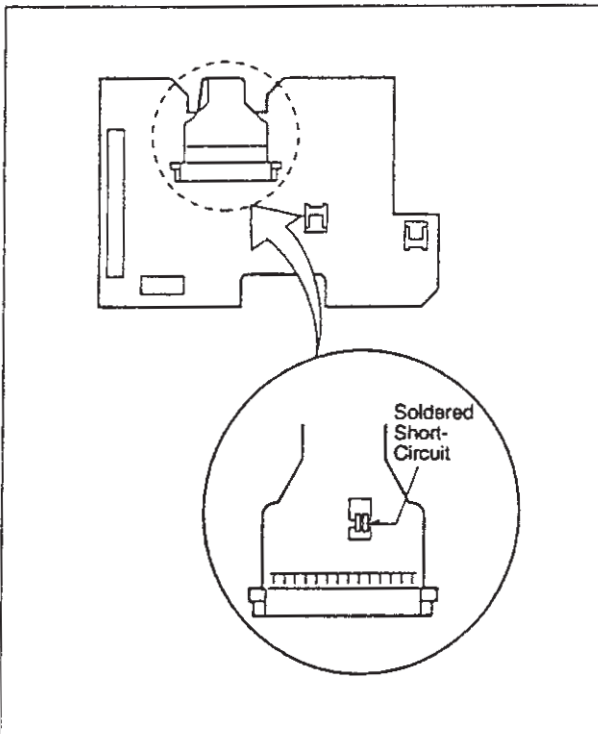

Fig. 3-A Short Circuit of the Laser Diode

Preparation Prior to Replacing the Parts

Always perform this work after taking action to prevent damage to the Laser Diode, regardless of whether or not the Laser Pick-Up is in working order.

1. Remove 2 connectors and 3 flexible cables on the Relay Board. FP0001–FP0003, FP0004 and FP0005.

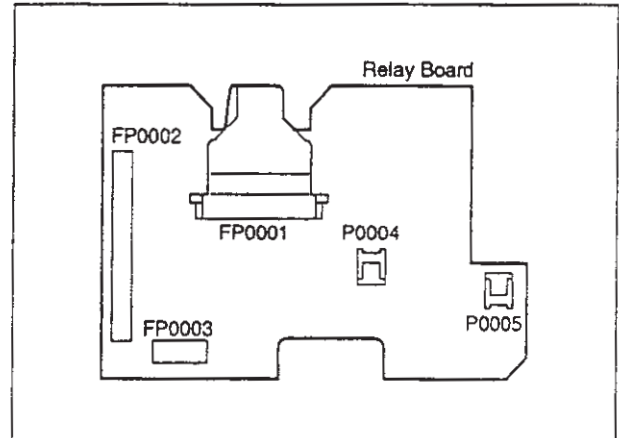

Fig. 3-B Relay Board

2. Remove the 3 screws, so that, traverse Unit can be separated into two sections.

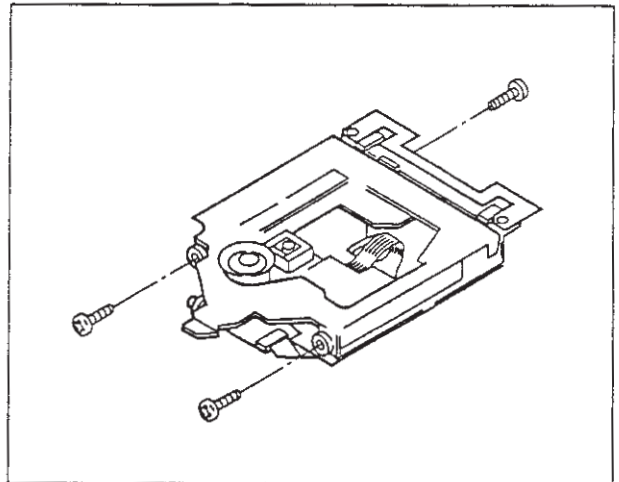

Fig. 3-C Disassembly of the Traverse Unit

3-1. Replacing the Laser Pick-Up

1. Remove the 2 screws.
2. Remove the Laser Pick-Up.

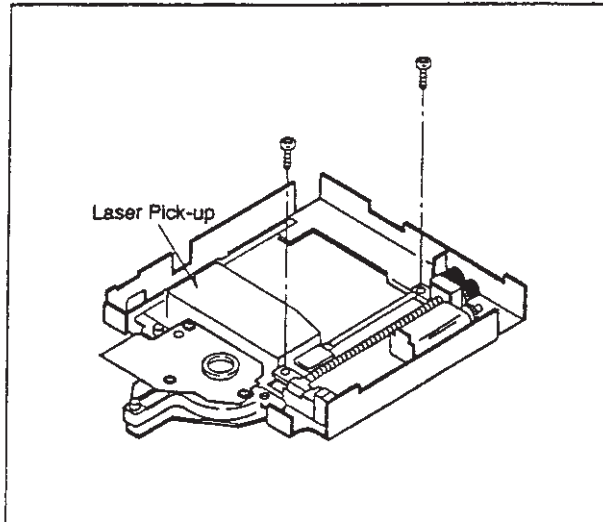

Fig. 3-1 Replacement of the Laser Pick-up

3-2. Replacing the Traverse Motor Unit

1. After the Laser Pick-Up has been removed, remove the 2 screws.
2. Remove the Traverse Motor Unit.

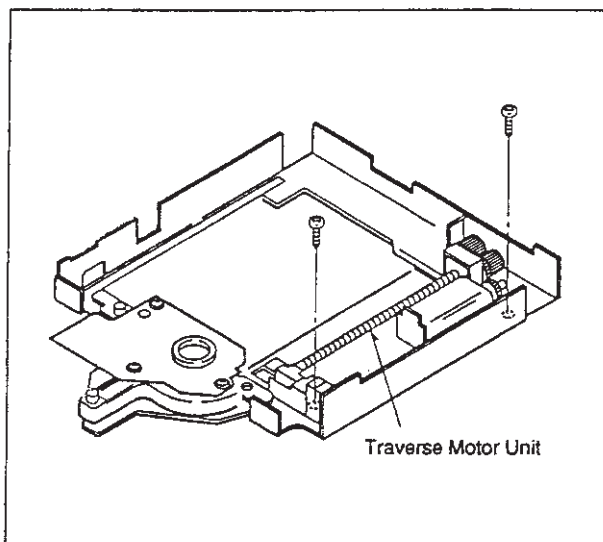

Fig. 3-2 Replacement of the Traverse Motor Unit

3-3. Replacing the Disc Motor

1. This disc motor can be removed after the Traverse Unit has been separated into two sections.
2. Remove the 2 screws A.
3. Remove the 2 screws B using an Hex. wrench.

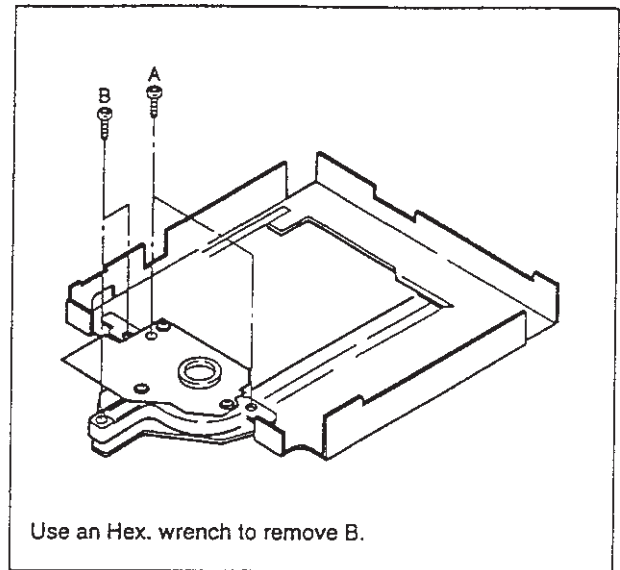

Fig. 3-3 Replacement of the Disc Motor

Note: It is not necessary to remove the Laser Pick-Up for replacement of the Disc Motor.

3-4. Disc Motor Assembly/Tentative Tilt Adjustment

1. For the Disc Motor assembling, install the 2 Screw B (adjustment screw) after firmly tightening the 2 Screws A. (Refer to the figure 3-3.)
2. Use the 2 Screws B to temporarily set the Disc Motor so that it rests parallel to the Base.

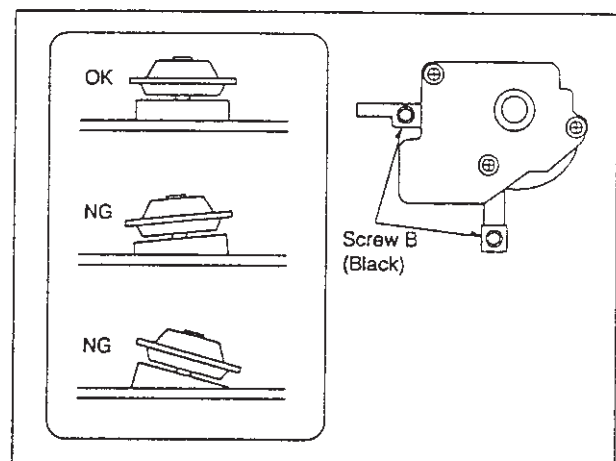

Fig. 3-4 Disc Motor Assembling

3. For final adjustment, proceed the Tilt Adjustment of Disc Motor (Page 2-12).

3-5. Others

1. Reassemble the Laser Pick-Up and the Traverse Motor Unit in precisely the reverse order as they were disassembled.
2. After reassemble the Laser Pick-up and the Traverse Motor Unit, perform the Tilt Adjustment of Disc Motor (Page 2-12).

4. Wiring Connection Diagram

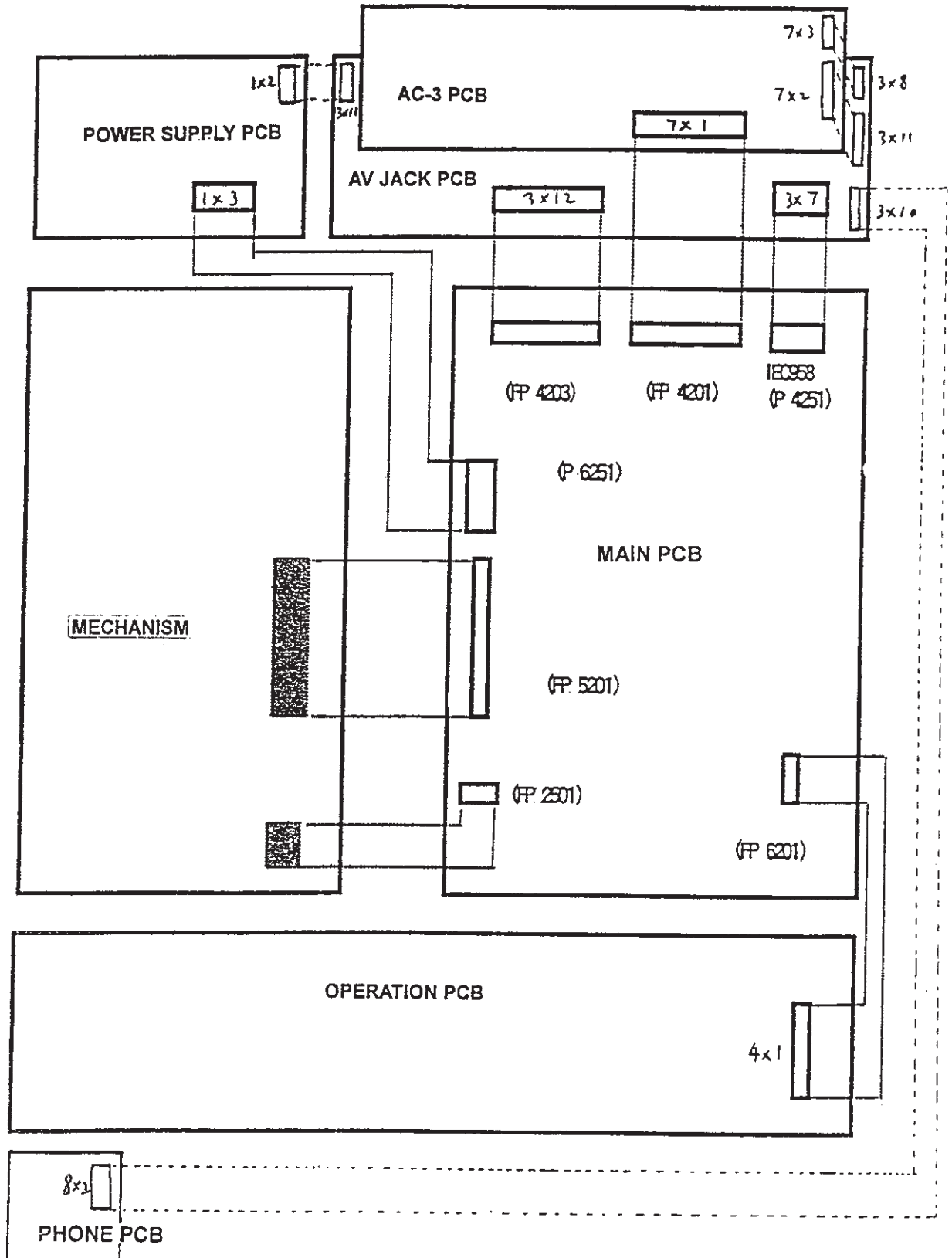

5. Disassembly and Check Method of Printed Circuit Board Assembly

5-1. Replacing the Main PCB

1. Remove 4 screws and check the Main PCB.

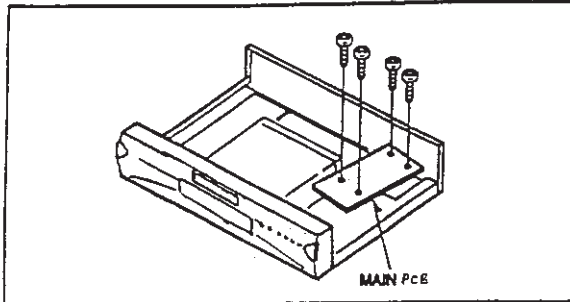

Fig. 5-1 Main PCB

When the Main PCB has been replaced, perform the initialization process.

5-2. Check Method of AV Jack PCB and AC-3 PCB

1. Remove 8 screws on the Rear Panel except for the 2 screws for holding SCART connector.

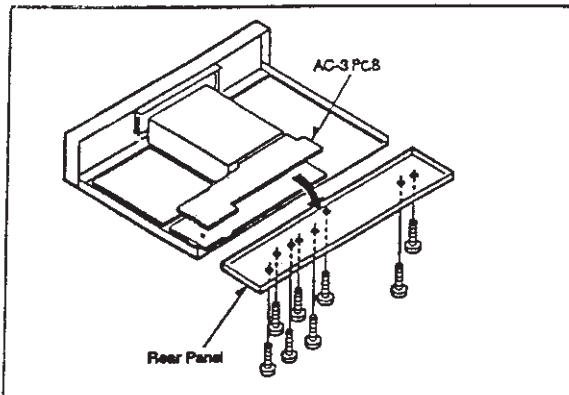

Fig. 5-2-1 Removal of Rear Panel

2. Remove 5 screws on the AC-3 PCB.
3. Remove the 2 screws holding SCART connector and 5 screws on the AV Jack PCB.
4. Disconnect the cables connected to the Power Supply PCB and Main PCB.

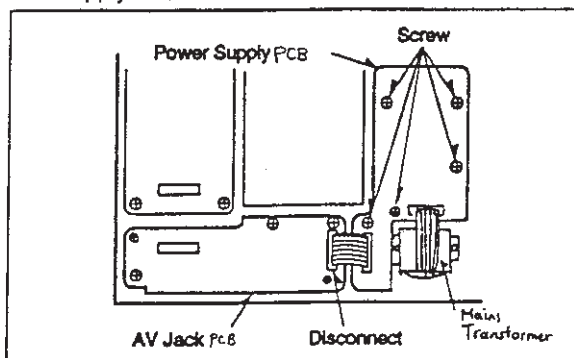

Fig. 5-2-2 AV Jack PCB

5-3. Check Method of Power Supply PCB.

1. Remove 5 screws on the Power Supply PCB.
2. Disconnect the cable connected to the AV Jack PCB.
3. Disconnect the cable connected to the Mains Transformer.

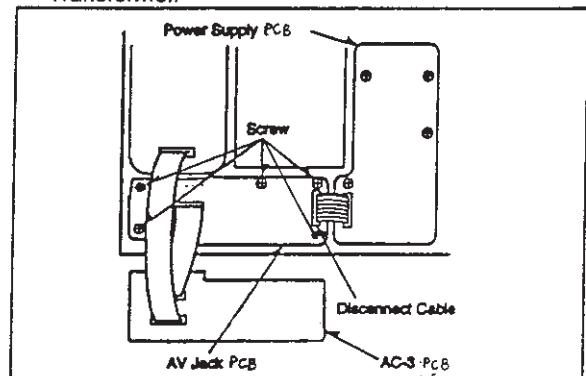

Fig. 5-3 Power Supply PCB

5-4. Check Method of Operation PCB

1. Refer to the disassembly procedure (Item 1-2) and remove the Front Panel.
2. Check the Operation PCB as the figure shown below.

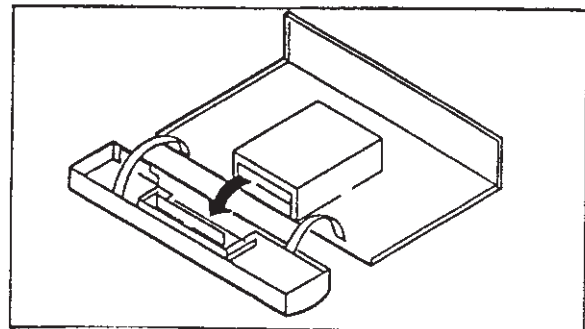

Fig. 5-4 Operation PCB

When the Operation PCB has been replaced, perform the initialization process.

6. Adjustment Procedures

Equipment Necessary for Adjustment

1. Measuring Equipments
General measuring equipments including an oscilloscope.
2. DVD Test Disc
Part No. DVDT-S01 (Single Layer)
3. Video-CD/CD-DA Test Disc
Part No. PVCD_K06
4. Multi-system TV Monitor
5. Others
Conventional tools, Hex. wrench 2.0 mm, etc.

6-1. Mechanical Adjustment Procedures

6-1-1. Tilt Adjustment of Disc Motor

After replacing parts in the Traverse Unit, it is necessary to adjust the Tilt Adjustment of Disc motor from bottom side. Please follow the following procedures for adjusting:

Caution:

1. Optical adjustment inside the laser pick-up is not possible.
2. Prior to adjusting, take countermeasures to prevent damage from static electricity.

When the following parts have been replaced, disc motor adjustment will be required.

1. The disc motor.
2. The laser pick-up.
3. The Traverse motor unit.
4. The parts around the laser pick-up (rail, etc.).

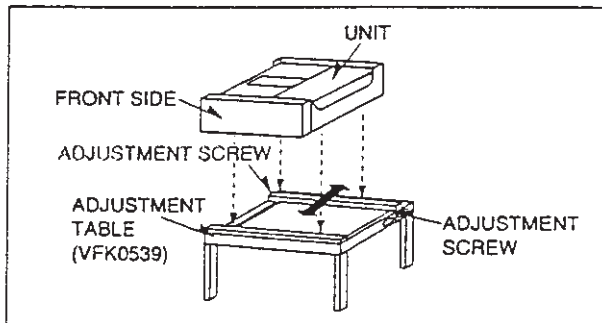

Fig. 6-1-1 Adjustment Table

Use a hex. wrench (2.0 mm) to adjust from the hole of the bottom plate.

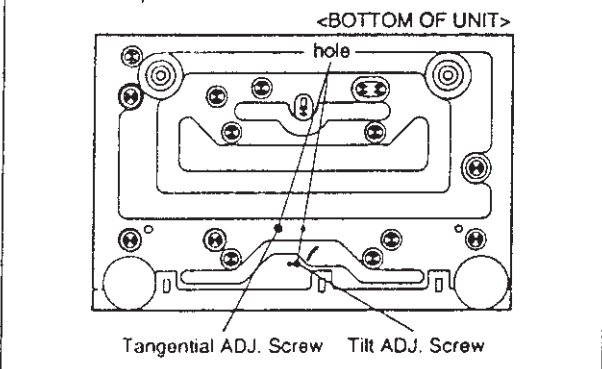

Fig. 6-1-2 Adjustment Hole of the Bottom Plate

Measurement Point	Adjustment Point	Mode	Test Disc
TL5206 GND: Chassis	Tilt adjustment screw	Play title 8, Pause	DVDT-S01
Measuring Equipment		Adjustment Value	
Oscilloscope DC 500mV/div., 20 msec./div.		Adjust until the bottom section of the waveform becomes flat and the DC components are minimum.	

Table 6-1 Tilt Adjustment

1. Play back the DVD test disc and then place the unit in play mode with title 8, then push the Pause button.
2. At first, Adjust Tangential Adjustment Screw then adjust Tilt Adjustment Screw with the Hex Wrench (2.0 mm) from bottom side.
Repeat 2 to 3 times alternately until the waveform at TL5206 indicated below is obtained.
Final adjustment should be Tilt Adjustment.
 - The valley sections of the waveform should be as flat as possible.
 - The total DC level should be obtained minimized as much as possible.
 - The waveform whisker sections will not disappear.

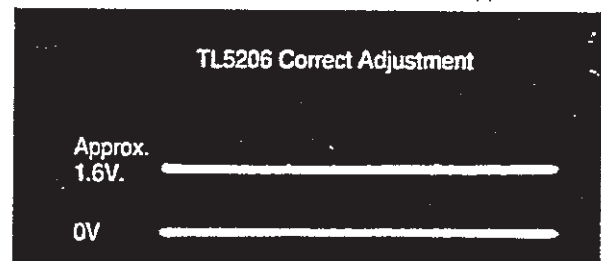

Fig. 6-1-3 Correct Tilt Adjustment Waveform

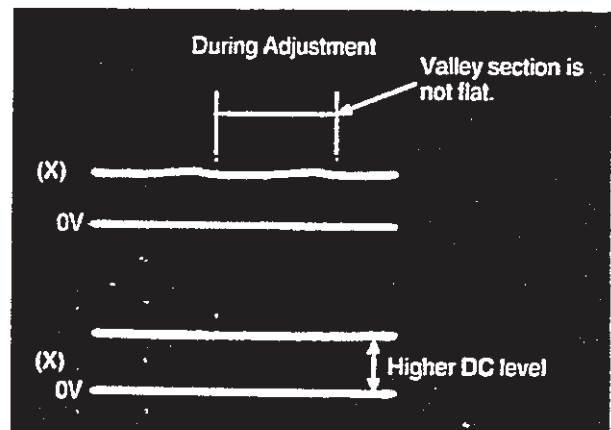

Fig. 6-1-4 Tilt Adjustment Waveform During Adjusting

After Adjusting Check the following

1. After adjusting by the DVD test disc, play a video CD or CD-DA and check that there is no abnormal operation.

6-2. Electrical Adjustment Produres

The following adjustment is electrical adjustments. These adjustments are to be performed after replacing the printed circuit boards.

6-2-1. Video Output (Luminance Signal) Adjustment

Measurement Point	Adjustment Point	Mode	Disc
Video Output Pin Terminal GND: Chassis	VR3232	Playback Title 12 (Colour Bar)	DVDT-S01
Measuring Device		Adjustment Value	
Oscilloscope 500 mV/div, 10 μ s/div		1000 \pm 20 mV p-p	

For compatibility of video signal output.

1. Connect the monitor TV to the video output terminal and terminate at 75 Ohms.
2. Play back the color bar part Title 12 of the DVD Test Disc title.
3. Adjust the VR3232 so that the luminance signal output is as shown below.
4. Confirm the signal on the AV Jack board side.

Adjustment Value = 1000 \pm 20 mV p-p

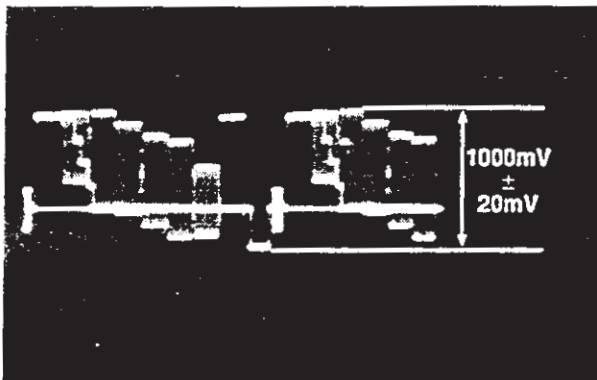

Fig. 6-2-1 Luminance Signal Output

6-2-2. Video Output (Chrominance Signal) Adjustment

Measurement Point	Adjustment Point	Mode	Disc
Video Output Pin Terminal GND: Chassis	VR3233	Playback Title 12 (Colour Bar)	DVDT-S01
Measuring Device		Adjustment Value	
Oscilloscope 500 mV/div, 10 μ s/div		671 \pm 13 mV p-p	

For compatibility of video signal output.

1. Connect the monitor TV to the video output terminal and terminate at 75 Ohms.
2. Play back the color bar part Title 12 of the DVD Test Disc title.
3. Adjust the VR3233 so that the chrominance (CYAN) signal output is as shown below.
4. Confirm the signal on the AV Jack board side.

Adjustment Value = 671 \pm 13 mV p-p

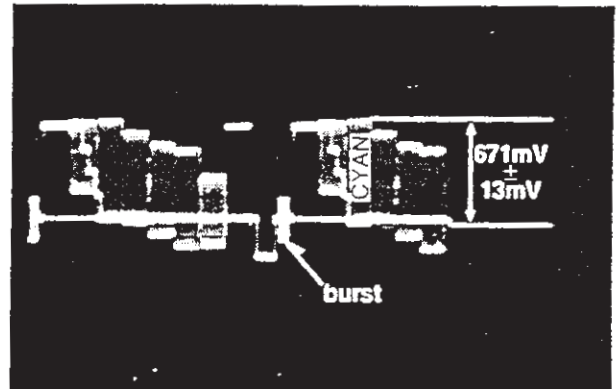
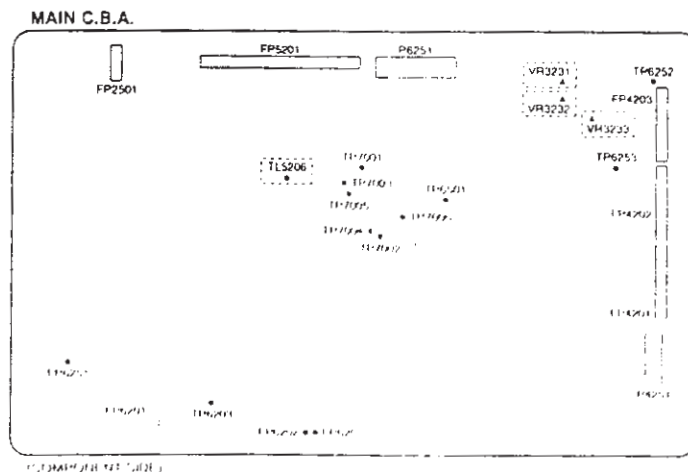
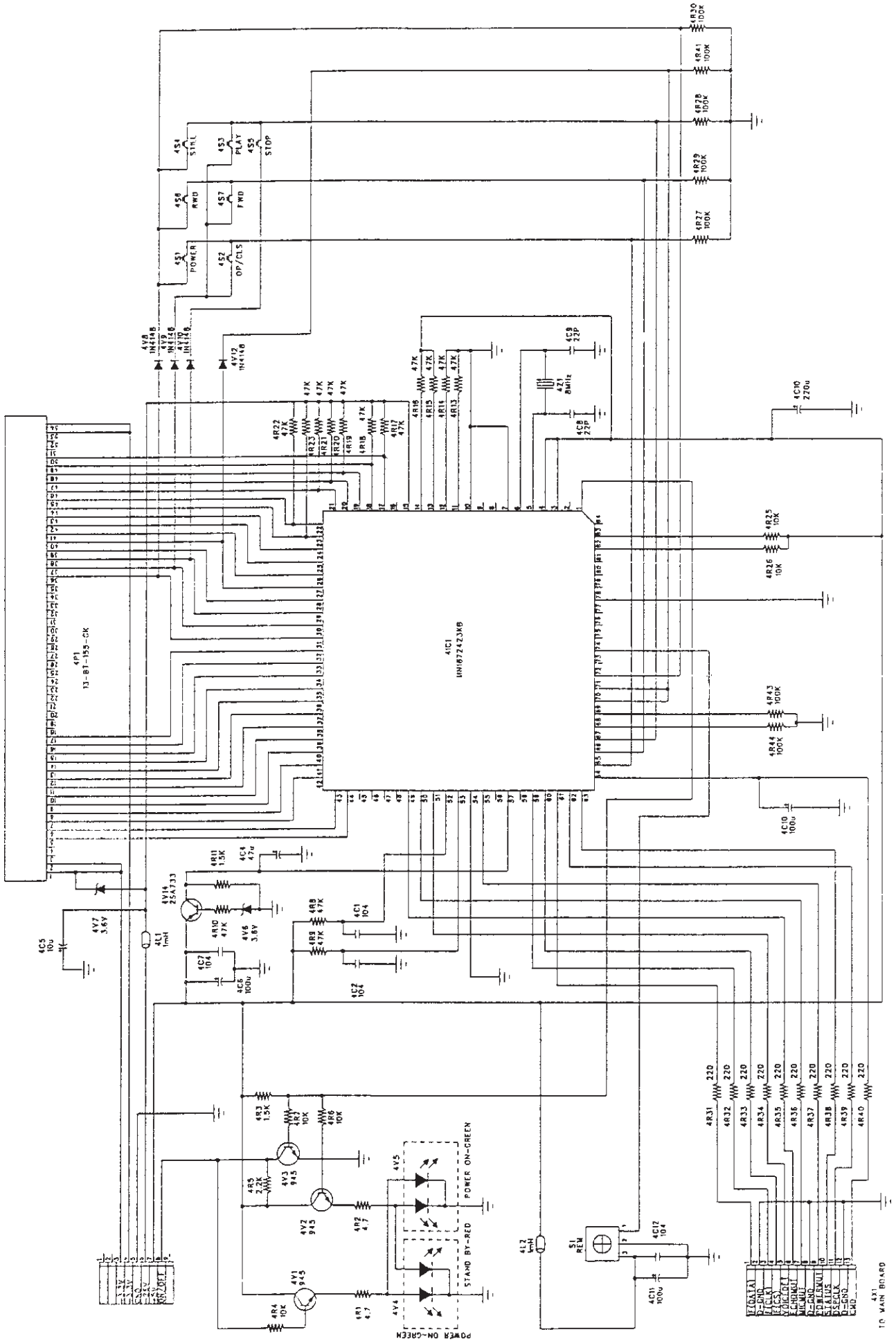

Fig. 6-2-2 Chrominance Signal Output

Test Points & Controls Location





Overall BLOCK DIAGRAM

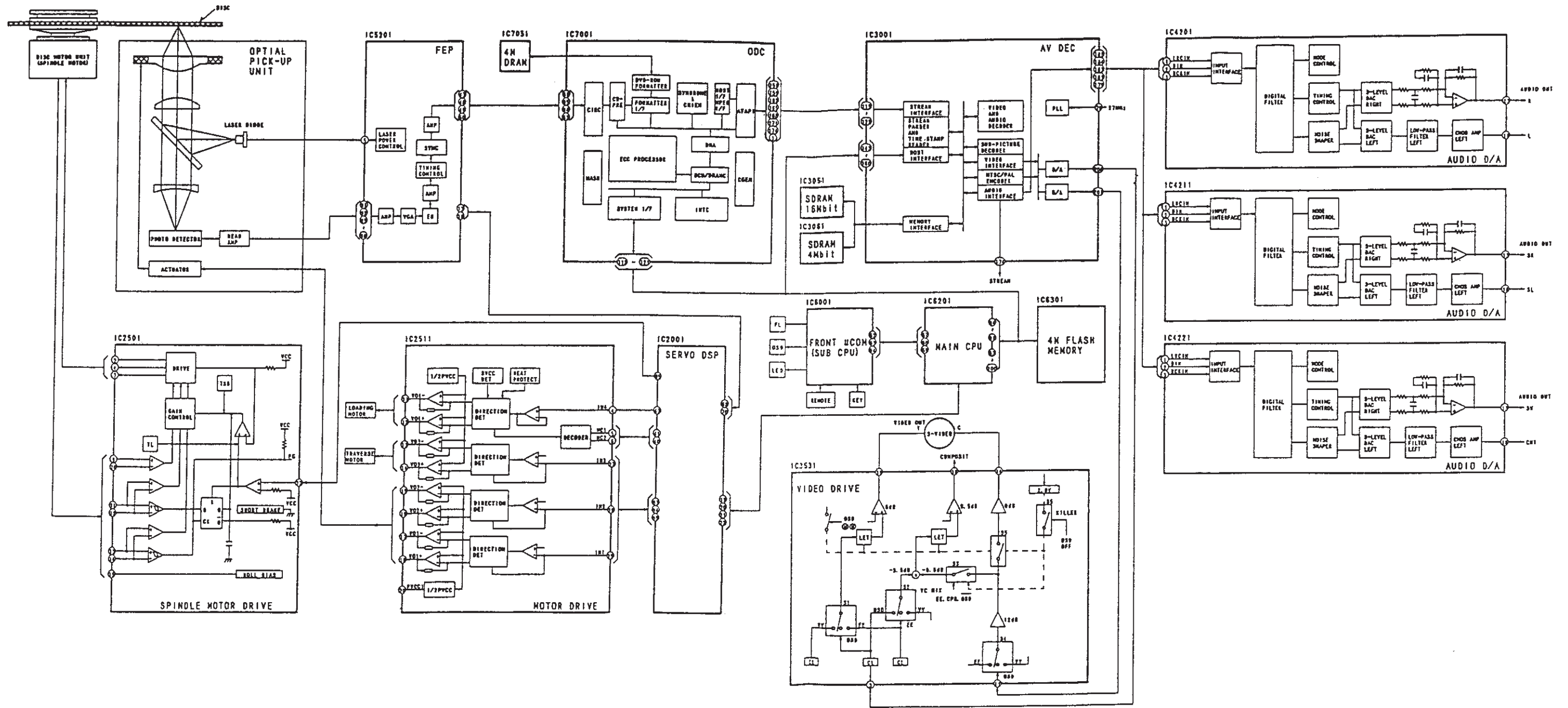

SCHEMATIC DIAGRAM

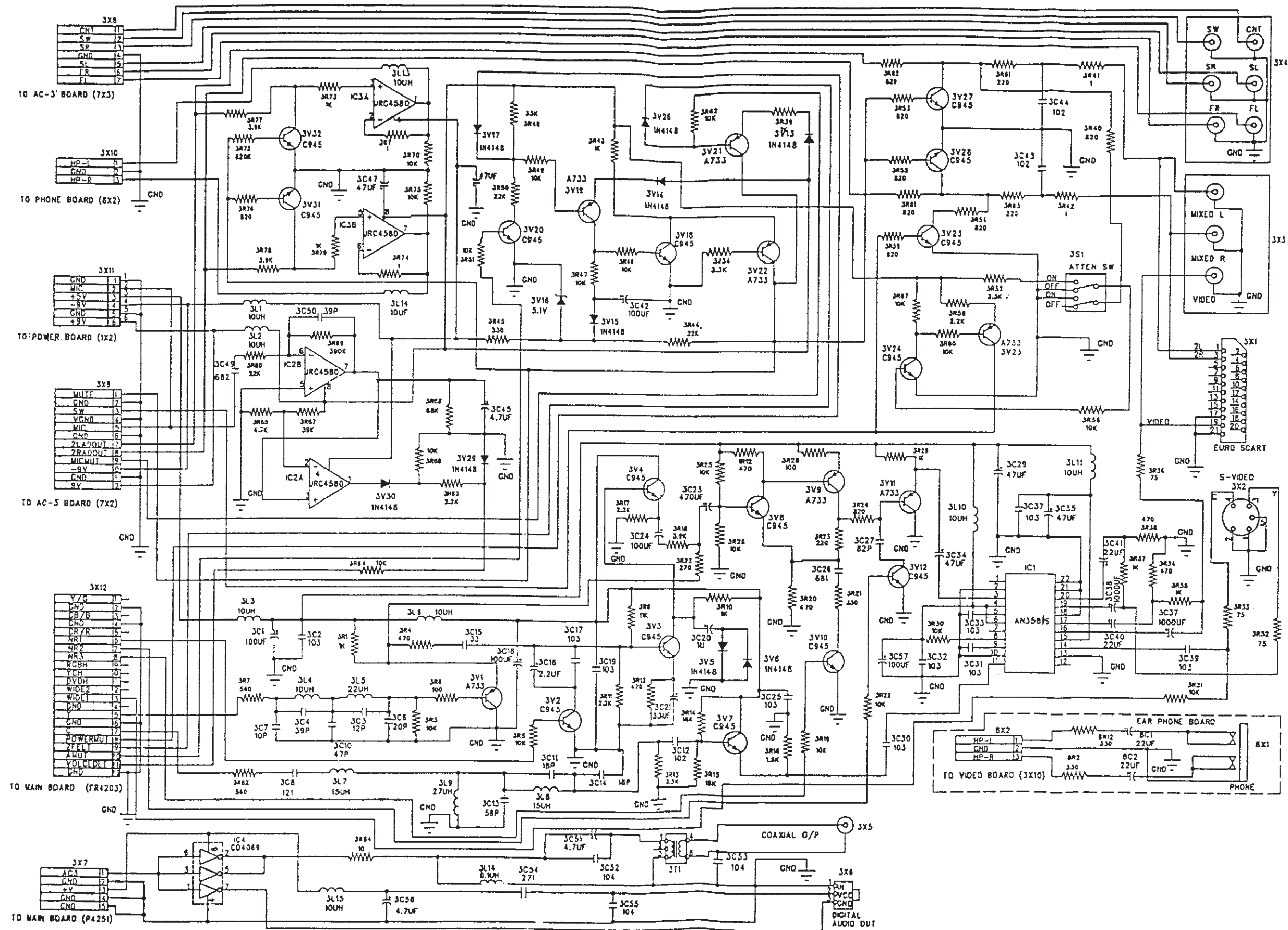

EXPLODED VIEW

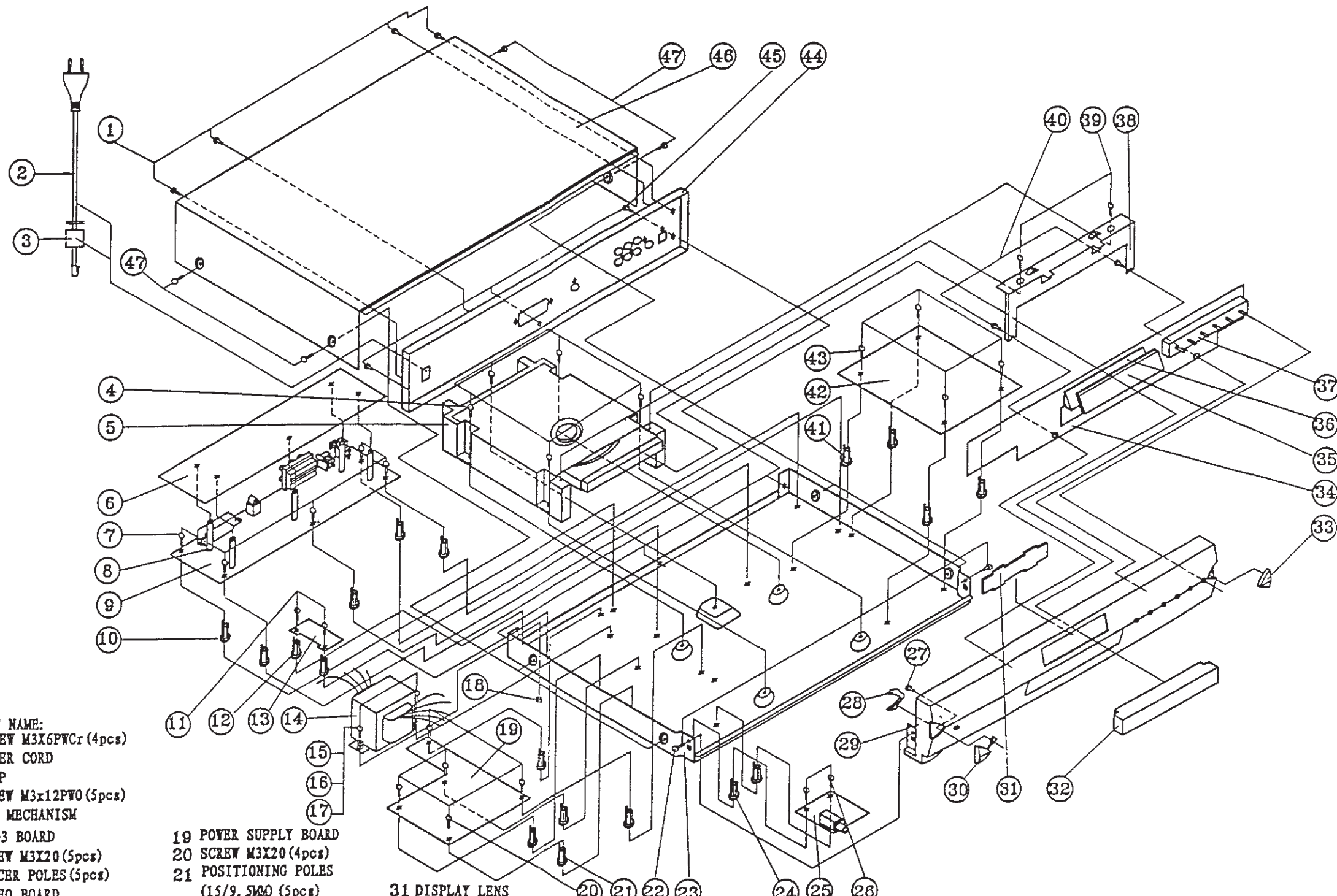

- PART NAME:**
- | | | |
|---------------------------------------------|----------------------------------------|---------------------------------------|
| 1 SCREW M3X6PWCr (4pcs) | 19 POWER SUPPLY BOARD | 31 DISPLAY LENS |
| 2 POWER CORD | 20 SCREW M3X20 (4pcs) | 32 DOOR |
| 3 CLIP | 21 POSITIONING POLES (15/9.5MM) (5pcs) | 33 REMOTE SENSOR LENS |
| 4 SCREW M3x12PW0 (5pcs) | 22 SCREW M4x6 (2pcs) | 34 FRONT BOARD |
| 5 DVD MECHANISM | 23 BOTTOM COVER | 35 VFD |
| 6 AC-3 BOARD | 24 POSITIONING POLES (20.5MM) (2pcs) | 36 VFD HOLDER |
| 7 SCREW M3X20 (5pcs) | 25 EARPHONE JACK BOARD | 37 OPERATIONAL BUTTON |
| 8 SPACER POLES (5pcs) | 26 SCREW M3x25 (2pcs) | 38 FRAME |
| 9 VIDEO BOARD | 27 SELF TAPPING SCREW ST2.6X6 (1pcs) | 39 SELF TAPPING SCREW ST3X8 (2pcs) |
| 10 POSITIONING POLES (15/9.5MM) (5pcs) | 28 POWER BUTTON LENS | 40 SELF TAPPING SCREW ST3X8 (2pcs) |
| 11 SCREW M3x20 (2pcs) | 29 FRONT PANEL | 41 POSITIONING POLES (15/13MM) (4pcs) |
| 12 POSITIONING POLES (15/9.5MM) (2pcs) | 30 POWER BUTTON | 42 MPEG DECODER BOARD |
| 13 FUSE BOARD | | 43 SCREW M3x20 (4pcs) |
| 14 TRANSFORMER | | 44 REAR PANEL |
| 15 SCREW M4X10Zc (2pcs) | | 45 SCREW M3X8PBO (3pcs) |
| 16 SPRING $\phi 4 \times 8 \times 1$ (2pcs) | | 46 TOP CABINET |
| 17 SPRING WASHER $\phi 4$ (2pcs) | | 47 SCREW M3X6PWCr (4pcs) |
| 18 NUT M4 (2pcs) | | |

SCHEMATIC DIAGRAM "A"

ADVEC and VIDEO-DAC Section

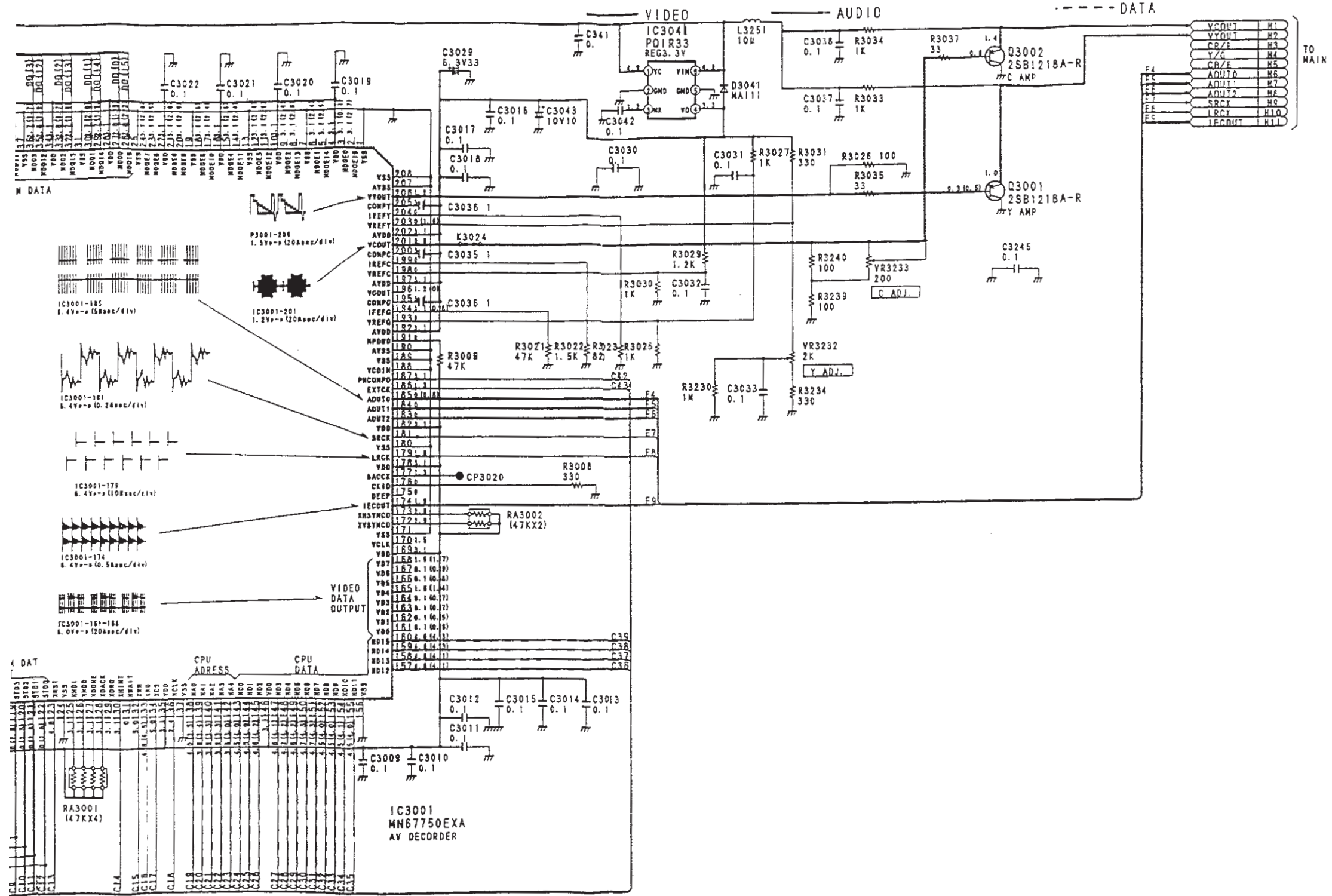

AV DECODER SECTION REF. NO. 23000 SERIES



SCHEMATIC DIAGRAM "B"

ODC and CPU Section

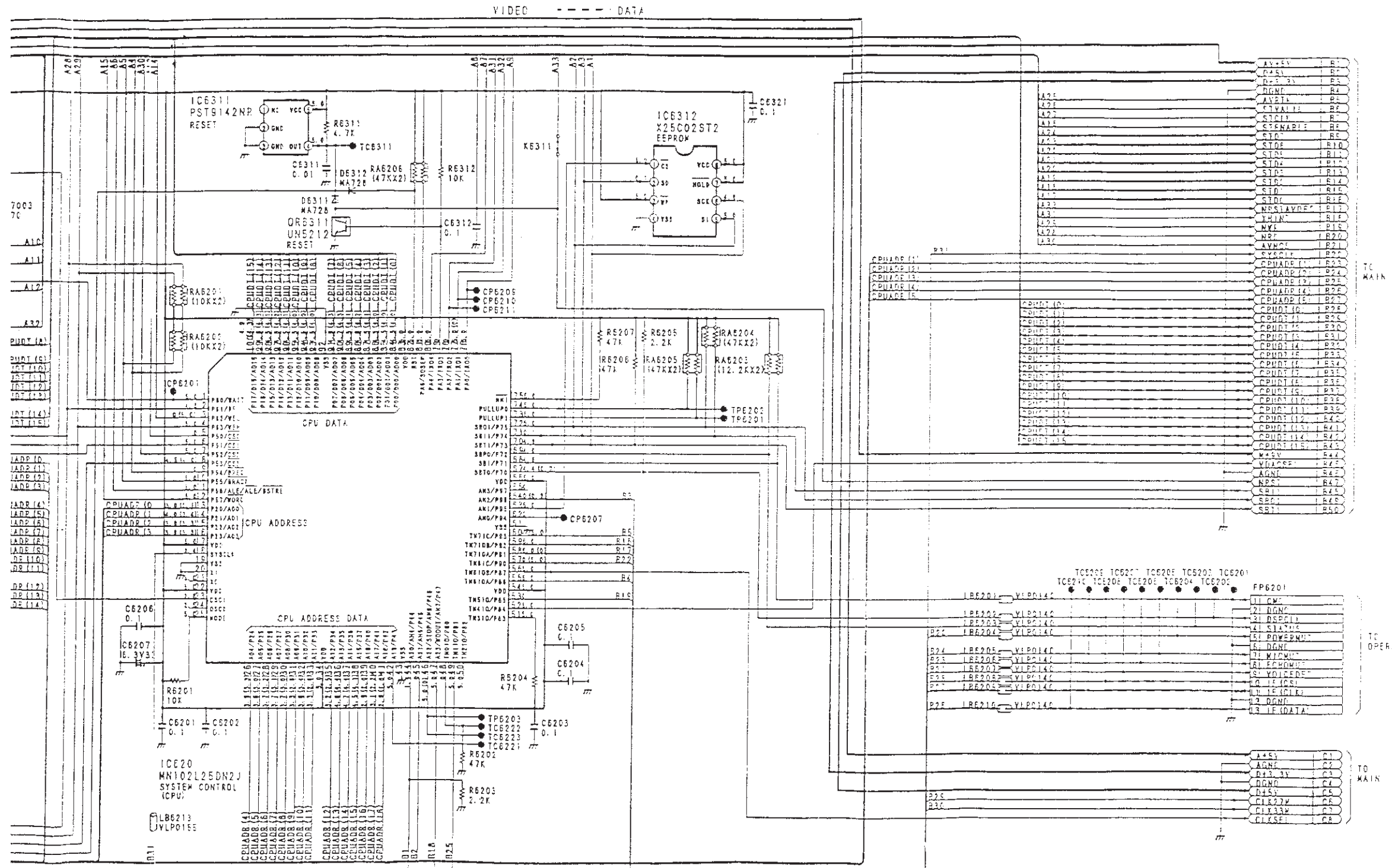

NOTE: THE MEASUREMENT MODE OF THE DC VOLTAGE IN THE BRACKETS () ON THIS DIAGRAM IS PLAYBACK MODE WITH DVD TEST DISC ITT. THE DC VOLTAGE OUT OF BRACKETS IS STOP MODE.



SCHEMATIC DIAGRAM "C"

FEP and ADSC and SERVO Section

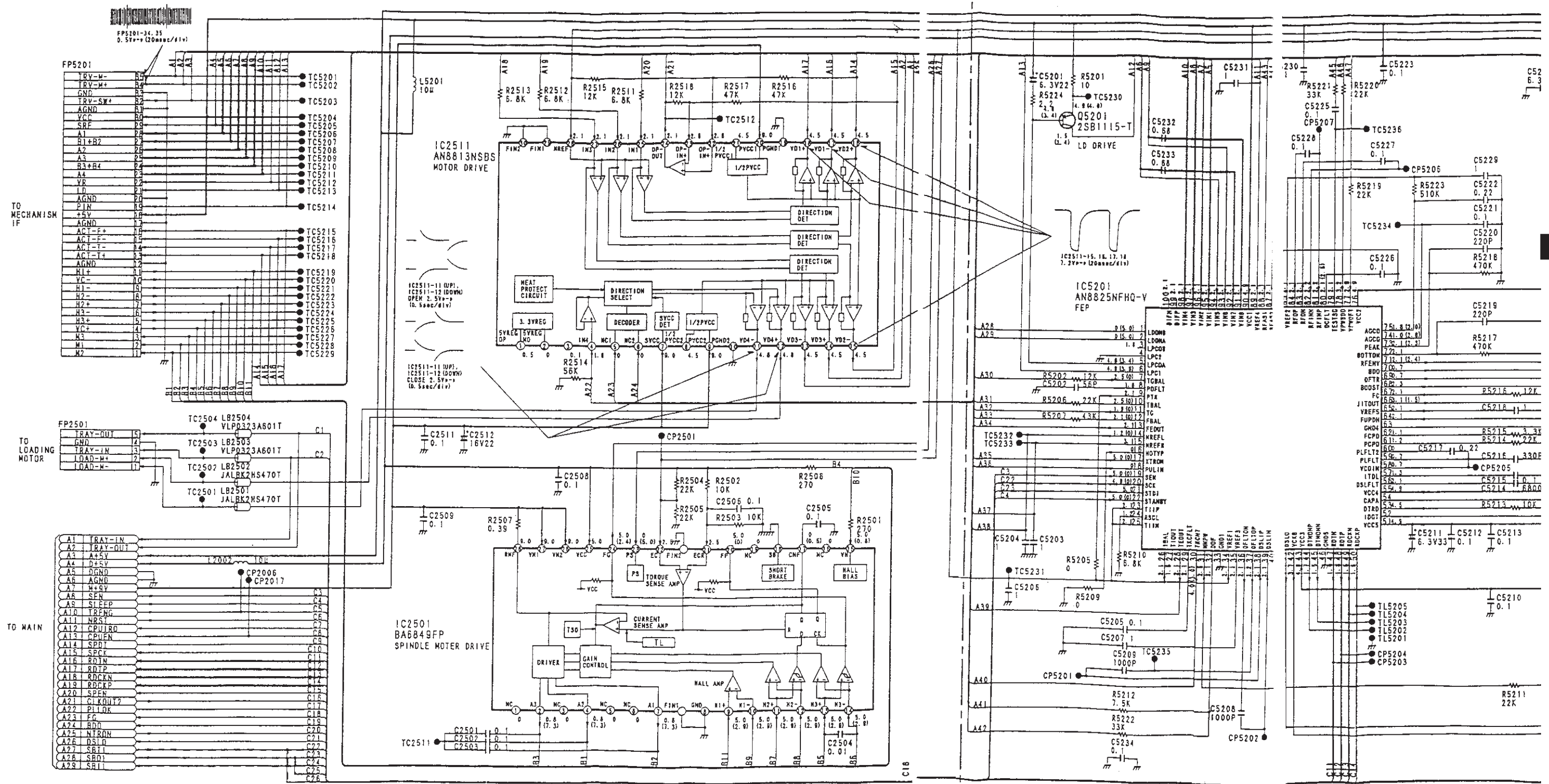

SERVO SECTION REF NO. 22500 SERIES

FEP SECTION REF. NO. 25200 SERIES



SCHEMATIC DIAGRAM "C"

FEP and ADSC and SERVO Section

